

FP - FPLF Aluminum Piston Vibrator



DESCRIPTION

The FP and FPLF series pneumatic piston vibrators produce a linear vibration with adjustable amplitude and frequency.

FP series needs a standard airline **lubrication**
FPLF series is completely **lubrication free**.

The frequency is controlled by adjusting the air pressure.
 A spring is used in the vibrator to assist starting.
 Minimum operating pressure 30 PSI

FEATURES

The aluminum **body** is hard coated and it is **corrosion resistant**.

There is **no paint** to flake off.

The **power-to-weight ratio** of the unit makes it particularly efficient for feeder applications.

Explosion proof, light weight and compactness make these units ideal for most applications.

Easy to install and designed to work continuously under the most demanding conditions.

The FPLF, being lubrication free, discharges **no oil mist** into the atmosphere.

With proper muffler these units are very quiet and usually below **75 dBA**.

Can be used at **temperatures** up to **280° F**

Nominal frequency **1800-9500 rpm**

Force Output **10 - 950 lbs**

PERFORMANCE DATA										
	FREQUENCY			FORCE OUTPUT			AIR CONSUMPTION			NOISE
	30 PSI	60 PSI	90 PSI	30 PSI	60 PSI	90 PSI	30 PSI	60 PSI	90 PSI	
MODEL	vpm	vpm	vpm	lbs	lbs	lbs	cfm	cfm	cfm	dBA
FP 12 S	6200	7800	9300	6	10	16	0.03	0.26	0.88	47-61
FP 12 M	5000	6000	6700	7.7	13	18	0.02	0.14	0.67	57-61
FP 12 L	4000	4800	5400	8	14	19	0.04	0.11	0.71	58-60
FPLF 12 M	5000	6000	6700	7.7	13	18	0.02	0.14	0.67	57-61
FP 18 S	5000	6400	7700	13	28	40	0.18	0.16	2.00	62-71
FP 18 M	4000	5000	5900	14	30	42	0.14	1.00	1.84	61-67
FP 18 L	3100	4000	4600	15	34	46	0.18	1.81	1.62	61-68
FPLF 18 M	4000	5000	5900	14	30	42	0.14	1.00	1.84	61-67
FP 25 S	3600	4300	5500	28	61	94	0.46	1.91	3.30	70-73
FP 25 M	3000	3800	4200	32	82	113	0.81	1.76	3.07	71-74
FP 25 L	2400	3100	3700	42	88	134	0.64	2.19	3.28	72-75
FPLF 25 M	3000	3800	4200	32	82	113	0.81	1.76	3.07	71-74
FP 35 S	3800	4700	5800	66	150	234	0.81	3.56	5.72	72-75
FP 35 M	3000	4000	4600	56	175	243	0.85	2.93	4.98	73-75
FP 35 L	2400	3100	3600	63	153	240	1.34	3.14	4.77	73-75
FPLF 35 M	3000	4000	4600	56	175	243	0.85	2.93	4.98	73-75
FP 50 M	1800	2300	2700	110	220	360	1.70	3.50	6.60	72-78
FPLF 50 M	1800	2300	2700	110	220	360	1.70	3.50	6.60	72-78
FP 60 M	1900	2400	2700	140	315	489	3.10	5.60	9.40	72-78
FPLF 60 M	1900	2400	2700	140	315	489	3.10	5.60	9.40	72-78
FP 95 M	1800	2400	2800	340	590	962	5.90	11.0	15.6	75-80
FPLF 95 M	1800	2400	2800	340	590	962	5.90	11.0	15.6	75-80

Thanks to truly low air consumption due to **tight clearance** between piston and housing, the FP-FPLF is one of the **most efficient** pneumatic vibrators available on the market.

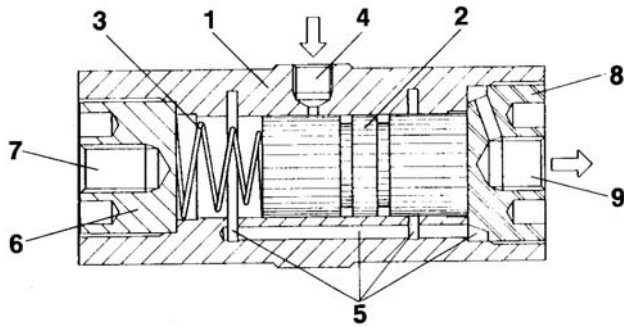

- | | |
|------------------------------------|------------------------------------|
| 1. Anodized aluminum alloy housing | 6. Anodized aluminum alloy socket |
| 2. Bronze piston | 7. Threaded base for mounting |
| 3. Starter spring | 8. Anodized aluminum alloy end cap |
| 4. Air inlet | 9. Air outlet |
| 5. Sound absorbing exhaust system | |

S stands for small amplitude

M stands for medium amplitude

L stands for higher amplitude

Construction

FP

Aluminum housing surface-hardened and corrosion resistant.

FPLF

Extra hard and Corrosion-resistant surface through aluminum oxide-generated by titaniferous electrolyte.

Maintenance guidelines

FP

5-micron filter necessary!

The FP requires a lubricator is for longer life. Only high grade air motor oil is to be used.

The airline filter must be inspected and cleaned at regular intervals. Dirt or contaminated oil will slow down or stop the vibrator.

DIMENSIONS

MODEL	A	B	C	D MOUNTING	E (BSP) INLET	F (BSP) OUTLET	WEIGHT (lbs)
FP 12 S	2.80"	1.22"	1.34"	M-8	1/8"	1/8"	0.32
FP 12 M	3.19"	1.22"	1.34"	M-8	1/8"	1/8"	0.37
FP 12 L	3.70"	1.22"	1.34"	M-8	1/8"	1/8"	0.45
FPLF 12 M	3.19"	1.22"	1.34"	M-8	1/8"	1/8"	0.37
FP 18 S	3.19"	1.57"	1.65"	M-10	1/8"	1/8"	0.62
FP 18 M	3.70"	1.57"	1.65"	M-10	1/8"	1/8"	0.75
FP 18 L	4.29"	1.57"	1.65"	M-10	1/8"	1/8"	0.9
FPLF 18 M	3.70"	1.57"	1.65"	M-10	1/8"	1/8"	0.75
FP 25 S	3.86"	1.89"	1.97"	M-12	1/8"	1/4"	1.17
FP 25 M	4.57"	1.89"	1.97"	M-12	1/8"	1/4"	1.43
FP 25 L	5.35"	1.89"	1.97"	M-12	1/8"	1/4"	1.74
FPLF 25 M	4.57"	1.89"	1.97"	M-12	1/8"	1/4"	1.43
FP 35 S	3.86"	2.28"	2.56"	M-12	1/4"	1/4"	1.86
FP 35 M	4.57"	2.28"	2.56"	M-12	1/4"	1/4"	2.29
FP 35 L	5.53"	2.28"	2.56"	M-12	1/4"	1/4"	2.82
FPLF 35 M	4.57"	2.28"	2.56"	M-12	1/4"	1/4"	2.29
FP 50 M	6.06"	3.33"	3.54"	M-16	1/4"	1/4"	7.15
FPLF 50 M	6.06"	3.33"	3.54"	M-16	1/4"	1/4"	7.15
FP 60 M	6.06"	3.74"	4.33"	M-16	1/4"	1/4"	9.35
FPLF 60 M	6.06"	3.74"	4.33"	M-16	1/4"	1/4"	9.35
FP 95 M	6.14"	5.51"	5.91"	N/A	3/8"	3/8"	20.7
FPLF 95 M	6.14"	5.51"	5.91"	N/A	3/8"	3/8"	20.7

