

VE1 Electric Vibrator

The POWTEK VE1 single phase rotary electric vibrator is built for tough applications with high operating loads and hostile environments

Housing is made of aluminum alloy up to size 660 and in ductile cast iron of high mechanical strength for all other frame sizes.

Units are rated continuous duty even at 100% force output.

Smaller models are with the new engineering design of "in-built flange" .

Bearings are larger for longer vibrator's life



Single-Phase 3600 RPM

PERFORMANCE DATA								
MODEL	FORCE OUTPUT	UNBALANCE	HP	AMP DRAW 115 V	STARTUP CURRENT MULTIPLIER	CAPACITOR SIZE (115v)	FRAME	WEIGHT
	lbs	in -lbs	h.p.	Amps		Micro farad		lbs
VE1/36/ 95	114	0.34	0.14	0.92	3.0	8	0	9
VE1/36/ 95 XL	167	0.45	0.14	0.92	3.0	8	0	10
VE1/36/120	167	0.45	0.20	1.35	3.2	25	1	11
VE1/36/120 XL	208	0.56	0.20	1.35	3.2	25	1	12
VE1/36/250	297	0.81	0.22	1.45	3.0	25	1	12
VE1/36/400	398	1.08	0.24	1.48	3.0	25	1	13
VE1/36/660	653	1.94	0.36	2.8	3.7	50	2	18
VE1/36/1050	1511	4.44	0.60	4.5	4.6	40	3	42
VE1/36/1650	1815	5.30	0.87	6.3	4.0	80	4A	61

FEATURES

The eccentric weights are easily adjustable so that force output can be varied on all models.

Low noise:
when fixed with a proper mounting to a rigid structure, noise never exceeds 70 dBA.

Low maintenance:
No lubrication - all models come with sealed bearings.

Lifting and safety eyebolts

Steel endcaps. Unlike aluminum endcaps, steel endcaps will not easily crack or leak.

Multiple bolt hole pattern to make it interchangeable with most of the other brands.

Quality control. Both electrical and mechanical components are subjected to strict tests. After assembly each electric vibrator is subject to severe electric and dynamic tests.



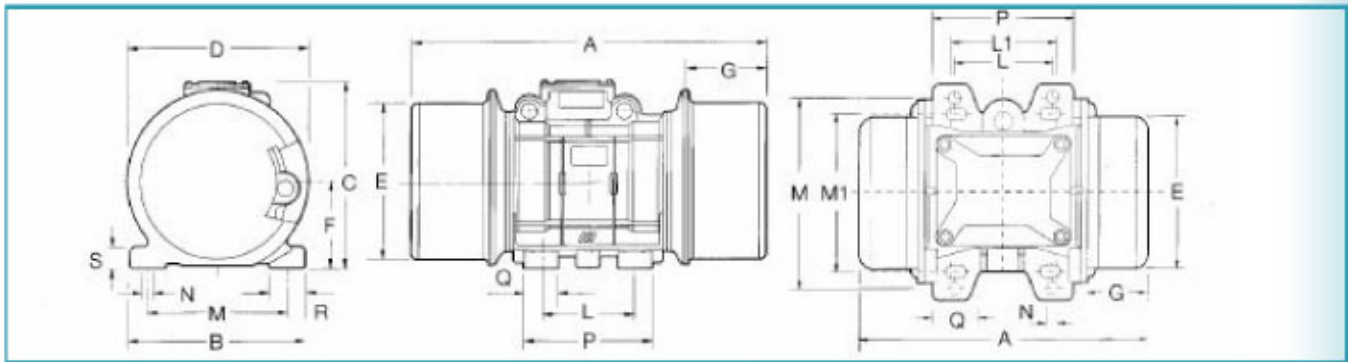

DIMENSIONS

MODEL	A	B	C	D	E	F	G	L	L1	M	M1	N	P	Q	R	S	BOLT HOLE NBR
VE1/36/95	7.65	4.92	4.80	3.42	3.23	1.81	1.38	2.44	-	3.86-4.17	-	0.35	3.89	1.18	1.22	0.32	4
VE1/36/95 XL	7.65	4.92	4.80	3.42	3.23	1.81	1.38	2.44	-	3.86-4.17	-	0.35	3.89	1.18	1.22	0.32	4
VE1/36/120	8.34	5.90	5.70	4.45	4.13	2.36	1.81	2.75	2.44-2.91	5.12	4.17	0.35	3.9	1.18	1.37	0.39	4
VE1/36/120 XL	8.34	5.90	5.70	4.45	4.13	2.36	1.81	2.75	2.44-2.91	5.12	4.17	0.35	3.9	1.18	1.37	0.39	4
VE1/36/250	8.34	5.90	5.70	4.45	4.13	2.36	1.81	2.75	2.44-2.91	5.12	4.17	0.35	3.9	1.18	1.37	0.39	4
VE1/36/400	8.34	5.90	5.70	4.45	4.13	2.36	1.81	2.75	2.44-2.91	5.12	4.17	0.35	3.9	1.18	1.37	0.39	4
VE1/36/660	10.24	6.54	7.28	6.30	5.12	2.95	1.97	3.54	3.54	4.92	5.51	0.51	4.72	1.18	1.57	0.47	4
VE1/36/1050	11.34	7.48	8.07	7.36	5.94	3.35	2.13	4.13	-	5.51	-	0.51	5.35	1.30	1.57	0.63	4
VE1/36/1650	13.98	8.27	9.29	8.50	7.13	3.98	2.80	4.72	-	6.70	-	0.67	6.30	1.57	1.69	0.79	4

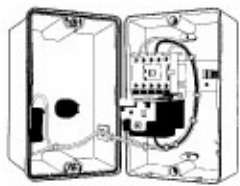

CONTROL BOX

Electric vibrators require overload protection following National Electric Code specifications. Powtek offers, as an option, a control box with ON/OFF switch and RESET push button.

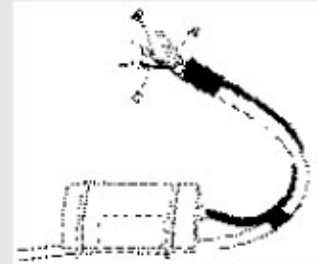

All models come standard with cable and capacitor

APPLICATION INDUSTRIES

BAKERY PRODUCTS CANNING AND PRESERVING CHEMICALS REFRACTORY
 CONCRETE PRODUCTS PRECAST AND PRESTRESSED MILK FEED MILL AND GRAIN
 WOOD AND LUMBER PULP AND PAPER PHARMACEUTICAL FOUNDRIES STEEL MILLS



CHICAGO VIBRATOR PRODUCTS

642 Newport Avenue
 Westmont, IL 60559
 1-800-842-7284
 1-630-920-9411
 WWW.CHICAGOVIBRATOR.COM
 solutions@chivib.com

