

VR Series High Frequency Roller Vibrators

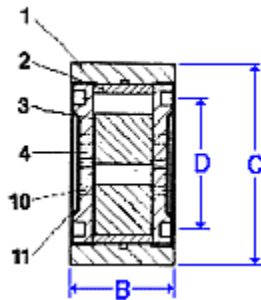
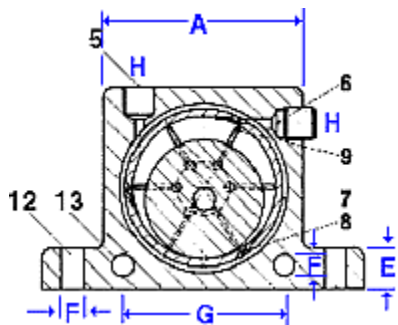

Construction:

- 1 - Extruded aluminum alloy body
- 2 - Cast iron liner
- 3 - Steel alloy roller
- 4 - Plastic end plates
- 5 - Vertical air inlet
- 6 - Horizontal air inlet
- 7 - Air groove
- 8 - Inlet jets
- 9 - Exhaust ports
- 10 - Exhaust diffuser
- 11 - Silencer plate
- 12 - Base mounting holes
- 13 - Lateral mounting holes

Dimensions:

Model	A		B		C		D		E		F		G		H	Weight	
	mm	inches	mm	inches	mm	inches	mm	inches	mm	inches	mm	inches	mm	inches		BSP Thread	kg
VR-50	50	1.97	29	1.14	86	3.38	68	2.68	12	0.47	7	0.27	40	1.57	1/8"	0.240	0.53
VR-65	65	2.56	37	1.46	113	4.45	90	3.54	16	0.63	9	0.35	50	1.97	1/4"	0.545	1.20
VR-80	80	3.15	43	1.69	128	5.04	104	4.09	16	0.63	9	0.35	60	2.36	1/4"	0.950	2.10
VR-100	100	3.94	52	2.05	160	6.30	130	5.12	20	0.79	11	0.43	80	3.15	3/8"	1.810	4.00
VR-120	120	4.72	77	3.03	194	7.64	152	5.99	24	0.94	17	0.67	NO LATERAL		3/8"	4.260	9.40

Performance:

Model	Frequency V.P.M. x 1000			Centrifugal force*						Air consumption / Minute					
	2 Bar 29 PSI	4 Bar 58 PSI	6 Bar 87 PSI	2 Bar N	29 PSI LBS	4 Bar N	58 PSI LBS	6 Bar N	87 PSI LBS	2 Bar Ltr.	29 PSI CF	4 Bar Ltr.	58 PSI CF	6 Bar Ltr.	87 PSI CF
VR-50	25.0	35.0	36.0	1.070	240	2.920	657	4.220	950	100	3.5	145	5.1	195	6.9
VR-65	19.0	21.0	26.0	2.730	614	4.830	1.089	6.120	1.377	200	7.0	300	10.6	400	14.1
VR-80	15.5	18.5	19.0	3.000	675	6.090	1.370	7.450	1.676	290	10.2	430	15.2	570	20.1
VR-100	11.0	14.0	16.0	3.750	844	6.750	1.519	8.900	2.003	370	13.0	550	19.4	730	25.8
VR-120	10.0	11.5	12.5	8.000	1.800	10.000	2.250	12.500	2.812	500	17.6	730	25.8	970	34.2

* Data obtained with a Kistler 3-axis dynamometer on a heavy laboratory test block and displayed by Kistler control monitor (COMO). Frequency and force will decrease on a less rigid mount. Specifications subject to change without notice or obligation.